

C7224

4½ Digit LCD Counter

An ultra-low power LCD counter which will find many applications, particularly in portable equipment. The module is supplied with a bezel incorporating an integral protective window and full mounting kit. Power supply requirements are either a regulated 5V source or alternatively a smoothed, though not necessarily stabilised, 7.5-15V supply. Outputs, including CARRY and LZB O/P, simplify the cascading of modules.

- 10mm (0.4") Digit Height
- Programmable Decimal Points
- DIN Cut-out
- Easily Cascadable
- High Count Rate
- TTL/CMOS Compatible Control Inputs
- Ultra-low Power



Standard Meter			Stock Number C7224	
Specification	Min.	Typ.	Max.	Unit
Maximum count			19999	compte
Oscillator frequency, Fosc.		19		kHz
Backplane frequency (Fosc ÷ 128)	150			Hz
Operating temperature range	0		50	°C
Supply voltage V+ (regulated)	4	5	5.5	V
Supply current (regulator isolated)			100	µA
Supply voltage (unregulated supply I/P)	7.5		15	V
Supply current (regulator input)		4		mA
Count I/P level (Schmitt Trigger)	Vth	2.5		V
	Vtl	2.0		V
Maximum count I/P level			±10	V
Input impedance		1		MΩ
Maximum count rate	10			MHz
Absolute maxima for control I/Ps: RESET, STORE, INHIBIT, OSC, LZB.	0		V+	V

DIMENSIONS All dimensions in mm (inches)

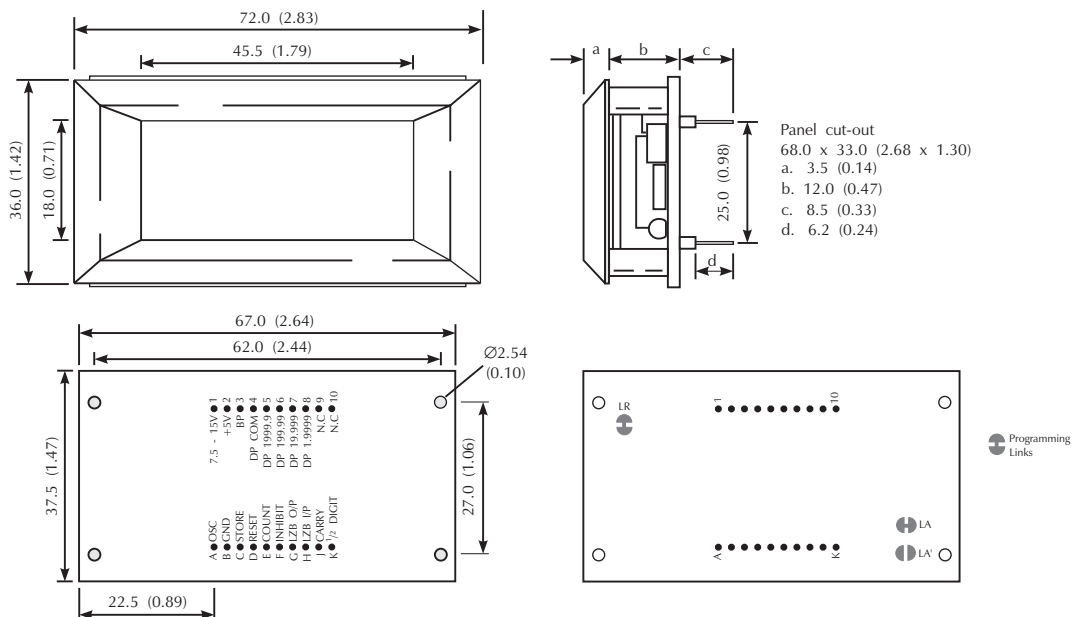

PIN FUNCTIONS

- A. OSC This input provides access to the on-chip oscillator, from which the Backplane is derived. The nominal frequency of 19KHz may be reduced by the addition of a capacitor (1 - 220pF) between this input and one of the supply rails. Connecting this pin to ground will disable the oscillator, allowing the Backplane to be overridden for external synchronisation. Care must be taken when exercising this option that a suitable Backplane signal is always present, otherwise D.C. will 'burn' the display.
- B. GND 0V, negative power supply connection. Count I/P and all logic levels are referenced to this pin.
- C. STORE Connect to 0V for normal operation. If left floating or connected to V+, the display will be held but the unit will still count. The display will be updated when STORE is returned to 0V.
- D. RESET Take this pin to 0V to reset the counter to zero. Otherwise leave floating or take to V+.
- E. COUNT I/P The counter increments on negative going transitions. Internal Schmitt trigger circuitry allows operation in noise-prone environments or for slowly changing inputs. To ensure reliable triggering, standard TTL/CMOS levels are recommended, so signal pre-conditioning may be required.
- F. INHIBIT Take this pin to 0V to disable the counter, otherwise leave floating or take to V+. Whilst inhibited, the module will ignore all incoming pulses to the count input.
- G. LZB O/P This pin will assume a high level (V+), when all digits of the display are blanked. This pin is for use in cascading and should in such cases be connected to the LZB I/P pin of the next least significant module.
- H. LZB I/P This pin controls the counter's leading zero blanking logic. It should be taken to V+ or left floating to blank leading zeros, or taken to 0V to display them. When operating modules in cascade only the most significant LZB I/P should be externally grounded.
- J. CARRY This output provides a negative going edge, which occurs immediately following the transition of the counter from X9999 to 10000. It may be used to provide the next significant count I/P in a multiple module system. A corresponding positive edge occurs immediately after the count of X6000 is reached.
- K. ½ DIGIT This pin is directly connected to the ½ digit drive. It may be used as an overflow 'flag' if suitably decoded with an exclusive OR gate and the Backplane 'signal'.
- 1. 7.5-15V Unregulated supply connection. If this option is used the supply should be smoothed though not necessarily regulated. Ensure that Link LR is shorted.
- 2. +5V Power supply connection. When this input is used ensure that Link LR is open (cut) to minimise power consumption. This pin may also power additional logic when the unregulated supply option is used. NOTE - In such instances the external load should be restricted to less than 10mA.
- 3. BP The Backplane is the 'Common' connection to the LCD, this O/P takes the form of a nominal 150Hz square wave and may be used either as a reference signal from which to decode segment O/Ps or alternatively as a 'pull-down' to suppress any unused LCD segments. When the on-chip oscillator is disabled, this connection becomes an input, which may be driven from the Backplane of another module or other suitable squarewave signal.
- 4. DP COM This is a logical inversion of the backplane signal. It may be used to drive the decimal points. Simply connect this pin to the required decimal point input.
- 5. DP 1999.9 } Decimal point select.
- 6. DP 199.99 } Decimal point select.
- 7. DP 19.999 } Decimal point select.
- 8. DP 1.9999 } Decimal point select.
- 9,10. N.C. Noconnection.

APPLICATION NOTES

CASCADING OF TWO MODULES
 Two or more counter modules may be cascaded to increase resolution to 8½ digits or more

AMPLIFICATION OF LOW LEVEL SIGNALS
 A comparator can be used to transform low level signals. D.C. rejection may be achieved by fitting a capacitor in series with the input.
 * A degree of positive feedback is recommended for stability. Component values may require optimising to achieve the full frequency response of the standard module.