

DMM 977

3½ digit LCD Autoranging Multimeter

The DMM 977 is a full function multimeter with 3½ digit numeric and 40 segment bargraph display. Automatic range selection is provided for both voltage (DC and AC) and ohms measurements. Two current ranges, 20mA and 200mA, can be manually selected. Two versions are available, the DMM 977S for single rail use and the DMM 977 for either 9V battery or split rail operation.

- 🔊 14mm (0.55") Digit Height
- 🔊 22 Ranges
- 🔊 40 Segment Bargraph
- 🔊 LED Backlighting
- 🔊 Digital Hold
- 🔊 Single Rail Version (DMM 977S)



CONNECTOR SOURCING GUIDE

METHOD Cable Mounting IDC Supplied With Product

OPERATING RANGES

NINE VOLTAGE RANGES

DC Voltage: 200mV, 2V, 20V, 200V, 2000V* (Max. I/P ±375V).
AC Voltage: 2V, 20V, 200V, 2000V* (Max. I/P 265V RMS)

FOUR CURRENT RANGES

DC Current: 20mA, 200mA
AC Current: 20mA, 200mA

NINE RESISTANCE RANGES

Standard Ohms: 200Ω, 2000Ω, 20kΩ, 200kΩ, 2000kΩ
Low Power ohms: 2000Ω, 20kΩ, 200kΩ, 2000kΩ

*Although the display range is 2000 counts, the maximum input voltage limit is ±375V for D.C. voltage and 265V RMS for A.C. voltage.

Stock Number
Standard Meter
Single Rail Version

DMM 977
DMM 977S

Specification	Min.	Typ.	Max.	Unit
Accuracy		0.5		% Rdg ± 1 count
(overall error *)	D.C. volts		0.75	% Rdg ± 8 counts
	A.C. volts		1	% Rdg ± 5 counts
	D.C. current 20mA range		6	% Rdg ± 5 counts
	D.C. current 200mA range		6	% Rdg ± 10 counts
	A.C. current		0.75	% Rdg ± 1 count
Resistance				% Rdg ± 1 count
A.C. frequency response	40 - 500Hz	1		% error
	500 - 2000 Hz	5		
Rollover error		±1		% Rdg
Operating temperature range	0		50	°C
Temperature stability		30		ppm/°C
Sample rate		2		samples/sec
Supply voltage (V+ to V-)	DMM 977	6.5	9	12
	DMM 977S	3.5	5	6
Supply current	DMM 977		1	
	DMM 977S		2	
Backlight current		50	90	mA

* To ensure maximum accuracy, re-calibrate periodically.

DIMENSIONS All dimensions in mm (inches)

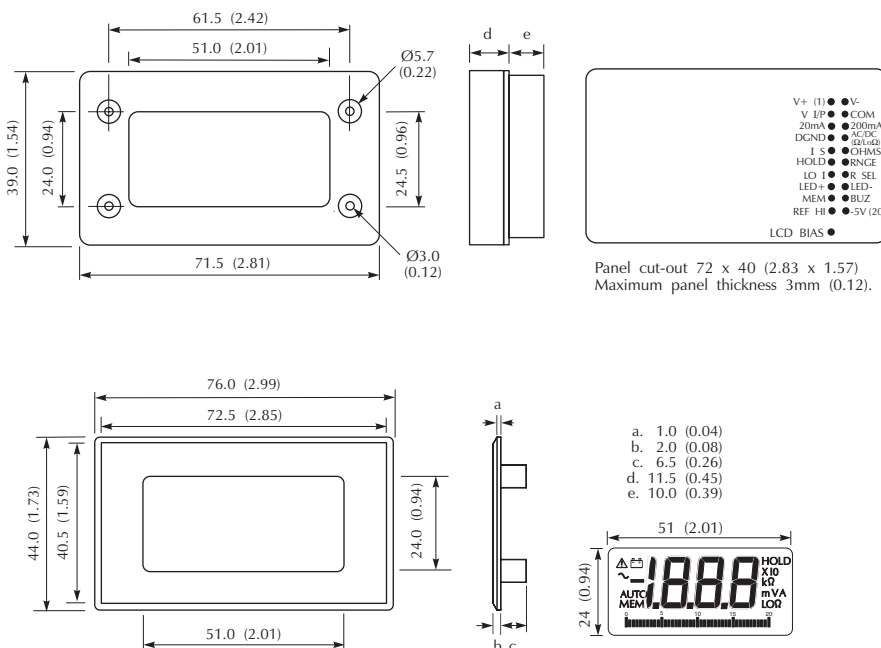



LASCAR ELECTRONICS LTD.
MODULE HOUSE, WHITEPARISH,
WILTSHIRE SP5 2SJ UK
TEL: +44 (0)1794 884567 FAX: +44 (0)1794 884616
E-mail: sales@lascar.co.uk

LASCAR ELECTRONICS INC.
3750 West 26th Street,
Erie, PA 16506 USA
TEL: +1 (814) 835 0621 FAX: +1 (814) 838 8141
E-mail: us-sales@lascarelectronics.com

LASCAR ELECTRONICS (HK) LIMITED
FLAT C, 5/FL., LUCKY FTY. bldg., 63-65 HUNG TO ROAD
KWUN TONG, KOWLOON, HONG KONG
TEL: +852 2797 3219 FAX: +852 2343 6187
E-mail: b4lascar@samsongroup.com.hk

PIN FUNCTIONS

1. V+ Positive power supply connection.
2. V- Negative power supply connection.
3. VI/P Voltage measurement input.
4. COM Analogue ground. Nominally 3V below V+.
5. 20mA Current measurement input 20mA range.
6. 200mA Current measurement input 200mA range.
7. DGND Digital ground. Nominally 4.7V below V+.
8. DC/AC (Ω/LoΩ) Take momentarily to DGND during voltage/current measurements to select either AC/DC measurements. Take momentarily to DGND during resistance measurements to select either ohms or lower power ohms measurements.
9. IS Connect to DGND (pin 7) for current measurement.
10. OHMS Resistance measurement input.
11. HOLD Connect to DGND (Pin 7) to hold display.
12. RNGE Take momentarily to DGND for manual range selection.
13. LOI Connect to DGND for 20mA range current measurement.
14. R.SEL Connect to DGND for resistance measurement.
15. LED+ Positive supply to LEDs for backlighting.
16. LED- Negative supply to LEDs for backlighting. LED+ to LED- supply voltage 5V.

SOCKET FUNCTIONS

17. MEM. Take momentarily to DGND to enter memory measurement mode.
18. BUZ. 4kHz output for continuity indication or overrange conditions.
19. REF HI. Input for external reference if required. Normally at 163.850mV above COM (Pin 4). Link 1 must be cut before external reference is applied.
20. -5V. Output from negative rail generator (DMM 977S only).

RESISTANCE, VOLTAGE & CURRENT MEASUREMENT SELECTION

The DMM 977 is designed to measure voltage, current and resistance. Autoranging is available for resistance and voltage measurements.

The Resistance Select pin (R.SEL) and Current Select (IS) input controls are normally pulled internally to V+. By taking these pins to Digital ground (DGND) the meter is configured internally to measure resistance, voltage or current. The required signal combinations are shown in the following table.

N.B. LO I (Pin 13) should be left floating or at V+ in all modes except when 20mA range is selected.

0 = DGND
1 = Floating or V+

Function Select Pin		Selected Measurement
	Current Select (Pin 9)	
0	0	VOLTAGE
0	1	RESISTANCE
1	0	CURRENT
1	1	VOLTAGE

MANUAL RANGE SELECTION

The DMM 977 voltage and resistance auto-ranging feature can be disabled by momentarily bringing RNGE (Pin 12) to DGND (Pin 7). When the change from auto to manual ranging occurs the first manual range selected is the last range which was used in the autoranging mode. Range changes are made by momentarily taking the RNGE pin to DGND. The meter will remain in manual range mode until the measurement function (voltage/resistance) or measurement option (AC/DC, Ω/LoΩ) is changed. To return to autoranging mode, take RNGE (Pin 12) to DGND (Pin 7) for a minimum of 2 seconds and release.

MEMORY MODE

Insert a pin into socket 17 (MEM) and take to Digital Ground (DGND) momentarily to enter this mode. The two least significant digits (LSDs) are stored and subtracted from future measurements. This mode can be very useful in resistance measurement when lead length resistance would cause measurement errors, or in tare measurements where a fixed value needs to be subtracted from each reading.

EXTENDED RESOLUTION MANUAL OPERATION

The DMM 977 extends resolution by 50% to 3000 counts when operated in the manual range. The extended resolution feature operates on the 2000kΩ range during autoranging operation. In the extended resolution operating mode, readings above 1999 are displayed with a 'flashing' 1 most significant digit (MSD). The 'flashing' 1 should be interpreted as the number 2. The three least significant digits display data normally. The bargraph will be fully extended.

LOW POWER OHMS MODE

The DMM 977 can be configured to measure in-circuit resistances shunted by semiconductor junctions. The low power ohms measurement mode limits the probe open circuit voltage which therefore prevents semiconductor junctions from turning on. To enter this mode take Pin 8 momentarily to DGND.

CALIBRATION

Use the following procedure to calibrate the module.

1. Perform calibration at an ambient temperature of $25 \pm 2^\circ\text{C}$ and a relative humidity of 80% or less. Allow the meter to stabilise at this temperature for at least thirty minutes.
2. Apply normal operating supply voltage to the meter and adjust potentiometer R until the voltage between REF HI (Socket 19) and COM (Pin 4) is 163.850mV.
3. Set the output of the calibrator to 1.900V and apply to the DMM 977 between Pins 3 and 4.
4. Adjust V potentiometer until the display reads 1.900.
5. Set the output of the calibrator to 19.00V pure sine wave at a frequency between 40 - 500Hz and again apply to the meter between Pins 3 and 4.
6. Take DC/AC (Pin 8) momentarily to DGND to enter AC mode.
7. Adjust potentiometer AC until the display reads exactly 19.00.
8. Disconnect calibrator, the meter is now fully calibrated.

CONTRAST ADJUST

The contrast for the DMM LCD is pre-set and should not need further adjustment, however, some users may wish to adjust the contrast or include temperature compensation for the LCD. To facilitate this, there is an additional socket, LCD BIAS (pin not fitted). To use this facility, Link Bias must first be opened and then a circuit connected as shown.

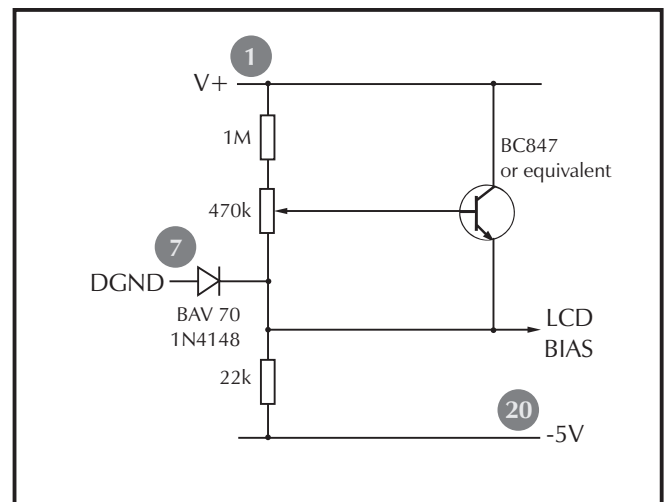

HEALTH AND SAFETY

1. When the DMM 977 is used for current or resistance measurements, an external fuse **MUST** be fitted.
2. When measuring voltages in excess of 60V peak, the systems, within which the DMM is incorporated, should conform to relevant sections of IEC 1010 (Safety Requirements for Electrical Equipment for Measuring, Control and Laboratory Use).
3. If this product is to be used for measuring mains supply voltages, external transient protection should be adopted.
4. Ensure that cable used for connection to the meter has a sufficient rating.
5. To comply with the Low Voltage Directive (LVD 93/68/EEC), input voltages to the module's pins must not exceed 60Vdc. If voltages to the measuring inputs do exceed 60Vdc, then fit scaling resistors externally to the module. The user must ensure that the incorporation of the DPM into the user's equipment conforms to the relevant sections of BS EN 61010 (Safety Requirements for Electrical Equipment for Measuring, Control and Laboratory Use).

METER PROTECTION

The meter should be protected against accidental application of high voltages on ohms and current ranges by a fast blow 5A fuse.

VARIOUS OPERATING MODES

The following diagram shows the basic measuring configurations.

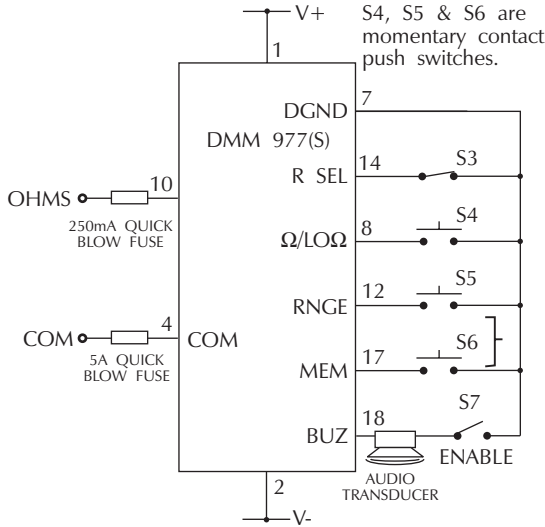

AUTORANGING RESISTANCE METER

S3 should be closed.
 Press S4 to toggle between Ω or $LO\Omega$ measurement mode.
 Press S5 to perform manual range changes.
 Press S6 to enter memory mode.
 With S7 closed the buzzer will sound whenever the reading is 19 counts or less.

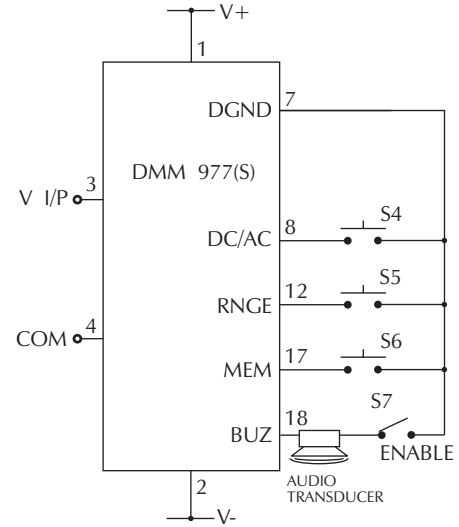

AUTORANGING VOLTAGE METER

The meter automatically enters voltage measuring mode on power up and will return to it if neither Current Select (IS) nor Resistance Select (R SEL) are taken to DGND.
 Press S4 to toggle between AC and DC measurement.
 Press S5 to select manual range changes.
 Press S6 to enter memory mode.
 With S7 closed the buzzer will sound to indicate an input overrange condition.

Resistance Select (Pin 14)

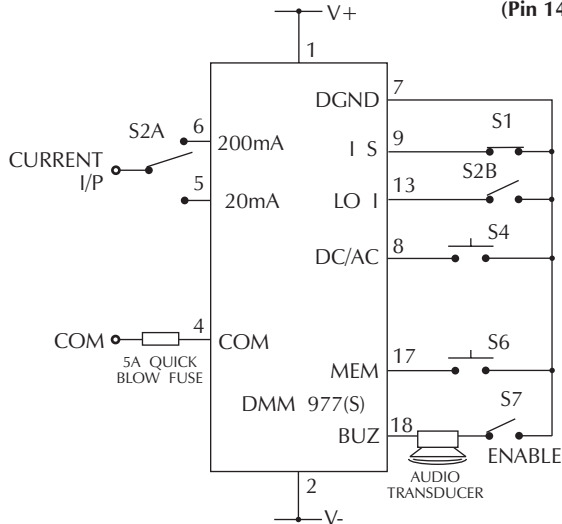

CURRENT METER

S1 should be closed.
 S2A range selects between the two current input pins.
 S2B selects 20mA range.
 Press S4 to toggle between AC and DC measurement.
 Press S6 to enter memory mode.
 With S7 closed the buzzer will sound to indicate an input overrange condition.

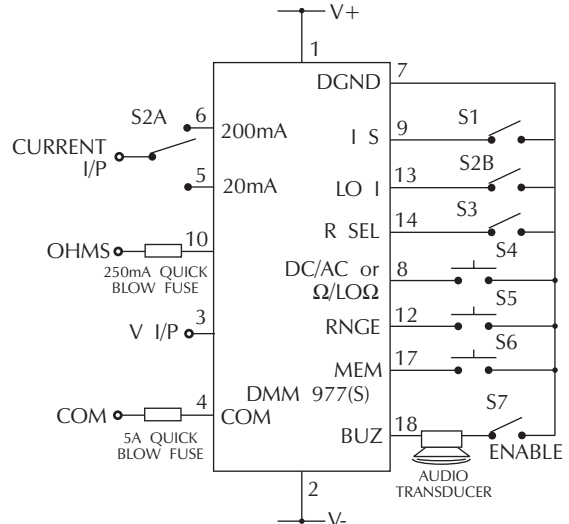

MULTIMETER

This diagram shows a complete multimeter constructed using the meter.
 S1 selects current measurement.
 S2A range selects between the two current input pins.
 S2B selects 20mA range.
 S3 selects resistance range.
 S4 toggles between AC/DC or $\Omega/LO\Omega$.
 S5 performs manual range changes.
 S6 selects memory measurement mode.
 S7 enables the audio transducer.