

A DIN cased 4-digit counter with high efficiency LED displays behind a red filter, giving a high contrast display under all lighting conditions. The counter is suitable for many applications such as batch counting, machine control etc. The counter can be pre-set (from BCD switches), compared to an internal register to give an 'equals' output, as well as providing a 'zero' output. All inputs and outputs are TTL/CMOS compatible.

- 🔊 14.2mm (0.56") Digit Height
- 🔊 Compact DIN Cased
- 🔊 Presettable Internal Register
- 🔊 Zero/Equal Output
- 🔊 Snap-in Panel Mounting
- 🔊 Up/Down Counting



Standard Counter				Stock Number C 790
Specification	Min.	Typ.	Max.	Unit
Supply voltage	4.5	5	5.5	V
Supply current		180		mA
Supply current with display blanked		1	5	mA
Input impedance		50		kilohms
Input signal level	3.5		±10	V
I/P frequency (counter)			2	MHz
I/P frequency (compare - register)	200	750		KHz
Display reading			9999	counts
Operating temperature range	0		50	°C

CONNECTOR SOURCING GUIDE

METHOD	
Terminal Block Adaptor Board	Available From Lascar - Stock No. T/BLK-2

DO NOT SOLDER DIRECTLY TO THE PINS - USE CONNECTOR SUPPLIED.

DIMENSIONS All dimensions in mm (inches)

Panel cut-out
68 x 33 (2.68 x 1.30)

Panel thickness
1.0 to 2.8 (0.04 to 0.11)

PANEL FITTING

Locate the meter by passing it through the front panel cut-out, gently pushing until the rear of the bezel is flush with the panel. The snap-in lugs will now automatically hold the meter firmly in position. Do not apply pressure directly onto the face of the red window.

PIN FUNCTIONS

- | | |
|-----------|---|
| 1. BCD8 | } BCD input/output connections can be used for pre-setting counter/register contents, or for monitoring counter contents. See Operating Modes for further details. |
| 3. BCD4 | |
| 5. BCD2 | |
| 7. BCD1 | } DIGIT SELECT OUTPUTS. Used for control of BCD data interfacing. Data is 4-way multiplexed by these outputs. See Operating Modes for further details. |
| 2. THOU | |
| 4. HUND | |
| 6. TENS | |
| 8. UNIT | |
| 9. RESET | Leave floating or connect to 0V for normal operation. Take to +5V to reset counter. |
| 10. EQUAL | Equal output is at a high level when contents of counter and register are equal. Normally this output is at 0V. Not valid during a Load Counter or Load Register. |
| 11. 0V | Negative power supply connection. |
| 12. ZERO | Zero output is at a high level when contents of the counter are 0000. Normally this output is at 0V. Not valid during a Load Counter operation. |
| 13. STORE | Display updates normally when pin is at 0V or left floating. If taken to +5V the display will be held, although the counter will continue to collect data. When returned to its quiescent state or taken to 0V, the display is updated. |
| 14. +5V | Positive power supply connection. |
| 15. U/D | When connected to +5V or left floating, the counter counts up. When connected to 0V it will count down. |
| 16. INHBT | Connect to +5V to inhibit counter input. Leave floating or connect to 0V to count normally. |
| 17. LDR | Leave floating for normal operation. Take to +5V to load BCD data into register. Take to 0V to blank display. |
| 18. DCONT | Leave floating for normal operation. Connect to +5V to blank display. Connect to 0V to inhibit leading zero blanking. |
| 19. I/P | Counts on negative-going transitions at up to 2MHz. |
| 20. LDC | Leave floating for normal operation. Take to +5V to load BCD data into counter. Take to 0V to force BCD I/O port to high impedance state. |

DECIMAL POINT LINKS

Place link across appropriate internal header on rear of display PCB.

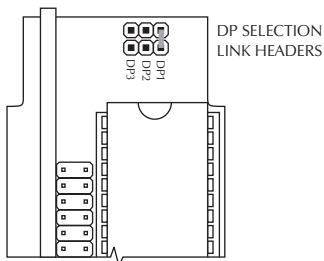

DE-BOUNCE COUNTING

For de-bounce counting at low frequency link pins 7 & 8 (internal) as shown below.

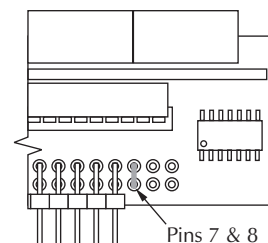

OPERATING MODES

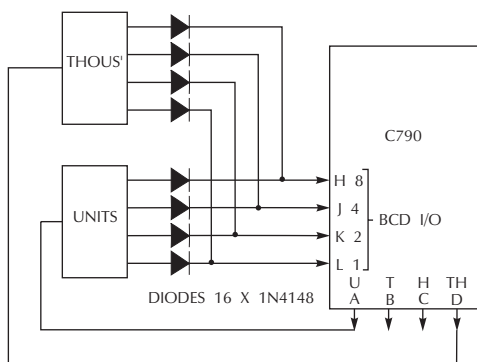

4 x TRUE BCD SWITCHES NEEDED
 (2 ONLY SHOWN FOR CONVENIENCE)

Loading of Data from BCD Switches

Thumbwheel switches may be connected as illustrated for applications where counter and/or register set points are required. The counter module controls the data transfer. It is not possible to synchronise it to any external systems.

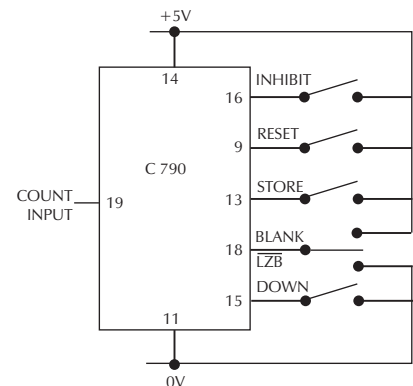

Typical Application