

# TECHNICAL HELPLINE

For technical assistance in integrating your Lascar panel instrument into your application or help in configuring your EasyLog® data logger please consult the product data sheet and refer to our frequently asked questions below. If you are still experiencing problems please contact one of our engineers, see below for contact details:

**UNITED KINGDOM** Tel: +44 (1794) 884567 E-mail: [technical@lascar.co.uk](mailto:technical@lascar.co.uk)

**UNITED STATES** Tel: +1 (814) 835 0621 E-mail: [technical@lascar.co.uk](mailto:technical@lascar.co.uk)

## GENERAL

**Q1. Can I have a data sheet on.....**

A1. Consult your appropriate sales office or download a data sheet right now.

**Q2. What are the storage conditions for a module ?**

A2. Although this varies from module to module, generally Storage Temperature range is from -25°C to the upper limit of Operating Temperature specified on the product's data sheet.

**Q3. Do you have any IP rated meters?**

A3. We have introduced the BEZ 900-IP bezel that will fit the 900 Series meters.

**Q4. Can Lascar supply a suitable power supply for my meter?**

A4. Yes. Consult our power supplies search page for the supply that is best suited to your application.

**Q5. Do you have a 1, 2 or 3 inch digit display?**

A5. No. we don't have a standard product available. However, Lascar provide a custom design service, please feel free to discuss your requirements with a member of our technical sales team.

**Q6. Do you have an Event Recorder ?**

A6. Yes, our EasyLog products can store a date and time upon a closed contact. A maximum of 1151 events can be stored on the 8 bit modules, 2000 events on the 12

**Q7. Which digital temperature meter should I select?**

A7. Lascar has three dedicated digital temperature meters. They can display °C & °F.

The EMT 1900 uses NTC technology with an onboard sensor; an external sensor can be added. The sensors are low cost but have a limited temperature range. The EMT 1900 has a temperature range of 10 to +50°C using the onboard sensor and 20 to +220°C using an external sensor.

The DTM 995 uses K type thermocouple technology. There is a large range of sensors available from various companies that cater for different temperature ranges and applications. The DTM 995 has a maximum temperature range of -50 to +600°C. Lascar can provide a probe that will measure across the range 0 to +600°C. For measurements where physical contact is not possible you can use an infrared sensor with a K type output with this product.

The DTM 910 uses PTC technology. There is a large range of sensors available from various companies that cater for different temperature ranges and applications. The DTM 910 uses a very accurate Pt100 type probe, 2, 3 or 4 wire operation and has a maximum temperature range of -200 to +850°C. Lascar can provide a probe that will measure across the range -50 to +250°C.

If you use an active probe with outputs such as a 4 to 20mA loop or a 0 to 10V signal then any Lascar DPM can convert these levels into temperature readings, see data sheet. Not all meters have the appropriate annunciators those that do are the DPM 300, DPM 400, DPM 500/S-BL, DPM 700, DPM 850S, DPM 2000/S or SM-1. In addition the SM-1 provides separately programmable high and low alarm outputs.





























**Q8. Where can I get external NTC Sensors for the EMT 1900 ?**

A8. The following are some suggestions :

BC Part No.	Construction	Temp Range	Farnell
2322-640-63103	Vertical PCB Mount.	-40 to +125°C	265-690
2322-640-54103	Vertical PCB Mount.	-40 to +125°C	279-572
2322-633-83103	Glass, Axial Leaded.	-40 to +200°C	984-632
2322-640-73103	Screw threaded stud.	-40 to +100°C	984-589

**Q9. How do I connect a K type thermocouple to the EL-1, EL-2, EL-2-IR or DTM 995, if the colour of the cable is not shown on the datasheet?**

A9. A table of international colour codes for K-type thermocouples is shown below:

 LASCAR	Sheath	Positive +	Negative -	Applicable Standard
European 	 Green	 Green	 White	IEC 584-3 / BS 4937 Pt.30
Intrinsically Safe	 Blue	 Green	 White	IEC 584-3 / BS 4937
British 	 Red	 Brown	 Blue	BS 1843
American 	 Yellow	 Yellow	 Red	ANSI MC96.1
German 	 Green	 Red	 Green	DIN 43714 or DIN 43710-4
French 	 Yellow	 Yellow	 Blue	NFE 42323 NFE 18001
Japanese 	 Blue	 Red	 White	JIS C 1610-1961

**Q10. Do we need a CE mark on Digital Panel Meters?**

A10. No. We regard our meters as components and thus not falling within the scope of the CE directive because they do not have an 'intrinsic function'. To apply a CE mark in these circumstances would, in fact, constitute a misuse of the CE mark.

**Q11. Is the meter millennium compliant?**

A11. Not applicable for panel meters.

# PANEL INSTRUMENTS

## **Q1. What is the maximum input voltage to a module ?**

A1. Our modules are generally configured for 200mV input. All meters can be scaled using resistors to read higher inputs. The data sheet has a table showing Ra and Rb values. Some meters have provision for fitting these components onboard. In this case we recommend that the maximum level applied should not exceed 60V. This restriction is due to the track spacing on the PCB.

## **Q2. The meter is reading '1' or '-1'. What is going wrong?**

A2. There are three possible causes:

1. The most likely is that the meter is being used with its inputs beyond their operating range. Check the data sheet and make sure that the inputs are well within the power supply rails. A good practical test for this on a non 'S-type' LCD meter is to replace power supply with an isolated 9V battery. If this works, it suggests that your existing power supply is causing the meters input to exceed the common mode input range. Remember that only an 'S-type' meter can have its inputs referred to the same supply as the meter.
2. The meter reference has not been connected. This will depend on the meter in question, but check the application notes on the back of the data sheet, especially the required link connections.
3. The input is too large!

## **Q3. The readings are unstable. What is going wrong?**

A3. The answer to this would fill a book. Consult our panel meter reference guide. Avoid placing the meter near to cables with large noisy currents in them. Check that ground loop errors are not causing signal offsets. Try an isolated battery supply and fit a 10 $\mu$ F capacitor between signal common and V+.

**Q4. So what's all this common mode input stuff anyway?**

A4. It depends on how much you want to know. In the simple case of measuring a differential input using a fully isolated power supply or battery you can pretty much ignore such errors. If you need a full spec run down on function, supply & input limits, then the best sources are IC manufacturers data on 71XX series from maxim, intersil, TelCom, etc.

**Q5. What are the scaling requirements of a module?**

A5. The scaling resistors Ra and Rb should be metal film, 1% tolerance and have a temperature coefficient of 50ppm/°C or less to minimise drift. Note you normally have to cut a link that is shorting out Ra. When scaling resistors have been fitted then it will be necessary to recalibrate the module. Please note that if potentiometers are used for scaling, their temperature coefficient will be greater than that of fixed value resistors. If measuring high voltages please remember that a standard leaded resistor typically has a maximum operating voltage of 250V (sometimes less).

Scaling for above 200V should always be external to the meter. Metal oxide resistors often have a higher breakdown voltage than metal film, at a penalty of a higher temperature coefficient, (actual specs should be carefully checked prior to use). Also bear in mind that scaling resistors should be of an adequate voltage rating for any transient, or fault conditions that may be experienced.

To change the scaling, use the following method.

Example, a 0 to 10V signal needs to display 0 to 500 (500 equates to 50mV).

Assume Ra is 1M. In our example Ra must drop 9.95V and therefore the current will be 9.95µA (Rb has very little effect once above 2V range). The value of Rb is therefore  $50\text{mV}/9.95\mu\text{A} = 5025\text{R}$ . The nearest preferred value would be 5K1.

Recalibrate by adjusting CAL pot on module.

[More rigorously  $V_{\text{METER}} = \frac{R_b}{(R_a + R_b)} \times V_{\text{EXT I/P}}$  See Figure 0]

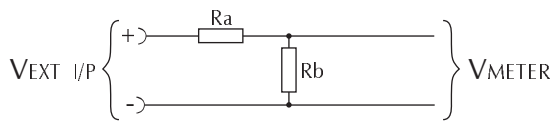

Figure 0

Required F.S.R.		
	Ra	Rb
2V	910k	100k
20V	1M	10k
200V	1M	1k
2kV *	10M	1k
200μA	0R	1k
2mA	0R	100R
20mA	0R	10R
200mA	0R	1R

\*Ensure Ra is rated for high voltage use.

For current measurement simply measure the voltdrop across a resistor (shunt). Ra is short circuit and the shunt resistor is fitted in the Rb position.

$$R_b = \frac{V_{\text{METER}}}{\text{Current I/P}} = \frac{200\text{mV}}{20\text{mA}} = 10\Omega$$

One must be taken that differential inputs (INHI, INLO) are not taken beyond their common mode operating range. For a standard meter this means a floating supply (e.g. battery) must be used. An S-type meter can use the same supply and have a common ground connection.

**Q6. How do I use multiple meters with the same PSU?**

A6. First you need to be fully familiar with both your own circuit and the common mode input range of the panel meter(s) in question. Refer to the IC manufacturer's original data, (Maxim, Intersil, TelCom, etc), for full details of common mode input limitations.

Once you have this information to hand you should now be in a position to work out the relative levels of each part of the circuit you wish to measure. Keep in mind you no longer have a simple case of an isolated differential measurement, you need to be aware of the absolute levels of connections you intend to make.

The most frequent mistake made when the negative inputs are commoned together, is to wire all the meters as fully floating types. In such a situation, only one meter's An Com connection should be used to establish the reference level for the negative measuring input. Dependant on type, you may need to cut links between An Com & In Lo, on the other meters to achieve this.

(The negative reference connection will still need to be made on each meter. Typically this is An Com to Ref Lo to Ref -. Depending on model type and default links made, some or all of these connections may already be in place). Refer also to the Panel Meter Reference Guide for further guidance and application examples.

**Q7. How do I use 2 meters to read Voltage and Current with a common PSU?**

A7-1. Non-S-type LCD meters, see example in Figure 1. Note that this is either powered from an isolated power supply or a battery in the range 7.5 to 14 volts.

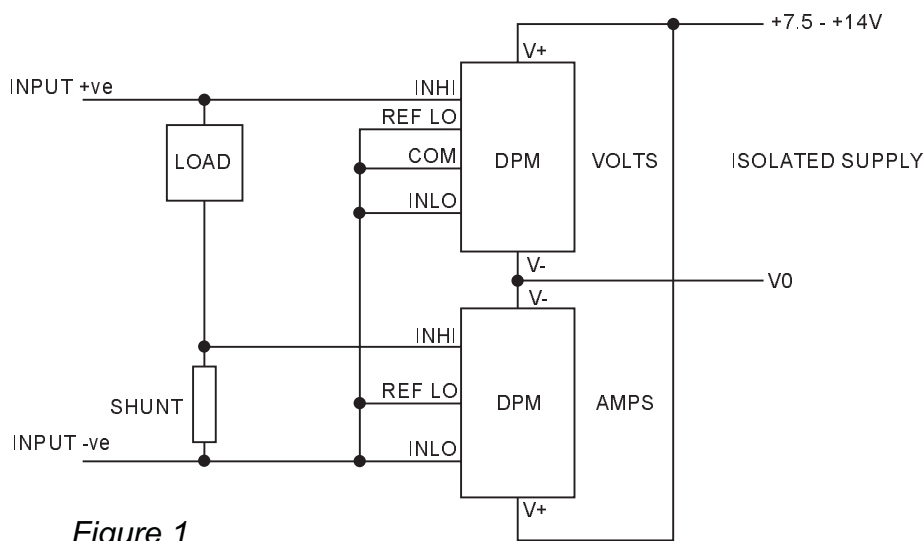

Figure 1

A7-2. LED and S-type LCD meters, see example in Figure 2. This may be powered from the supply being measured and is typically in the range 4.5 to 5.5 volts.

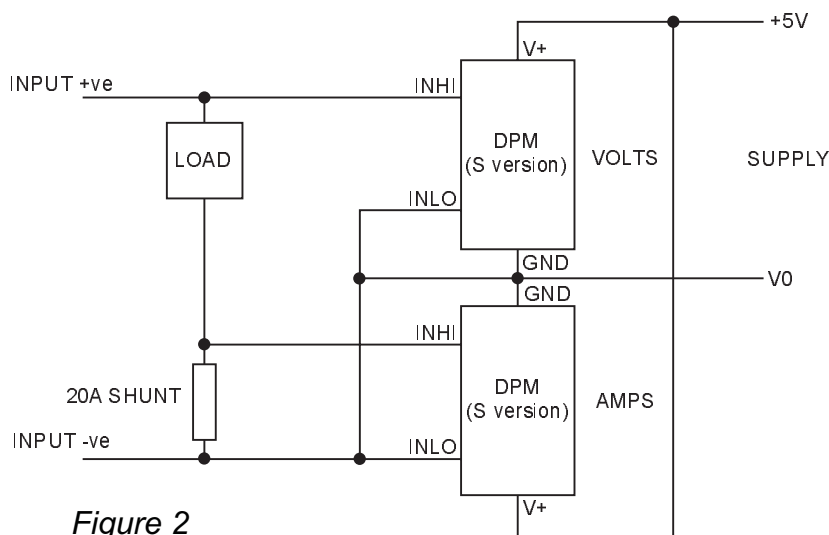

Figure 2

**Q8. I am using a dc/dc converter to obtain an isolated supply, but the display is unstable, help?**

A8. DC/DC converters typically need a minimum load of 10% to become stable. In addition because of the converter's hf switching spikes may be present on the supply to the module. The manufacturers will probably detail additional filtering which should improve the situation. Remember the standard requirements such as short leads, decoupling capacitors and ferrite beads may improve the situation.

**Q9. My application uses a Lascar 'SP 400'. I designed the circuit, based on the old Iss '2' PCB version, but when I fit the latest Iss '3' PCB version, the backlighting no longer works. What has gone wrong ?**

A9. The Backlight connection BL- (Pin 3), now needs to be connected to 0V, to turn-on the backlight. (This applies to the Single-Rail Power Supply mode connection, assuming a supply voltage of 5V. For the floating (9V nom) configuration, or single-rail supply voltages greater than 5V, refer to the SP 400 Data Sheet Iss **6** or later).

This change has been made to allow backlight operation, in both single-rail and fully floating power supply configurations. (It was previously unavailable for the floating (9V) supply option). This latter supply mode option was a late addition to the original spec, which until recently has precluded a backlighting option due to logistics. You will not damage a new Iss **3** PCB version **SP 400** by fitting it to a (single-rail) circuit wired for the previous Iss **2** PCB version. Rather the backlight, will not turn-on until BL- (Pin 3), is re-wired to 0V. (Previously Pin 3 was designated BL+ and taken to +5V, to enable backlighting). Similarly you will not damage an old Iss **2** PCB version **SP 400**, *if configured for single-rail 5V operation*, if your circuitry is wired for the new Iss **3** PCB version.

We recommend you exercise caution if using the 9V (floating) supply mode, as if an old Iss **2** PCB version part is fitted in error, the LED backlight could be reverse biased. Lascar is now shipping exclusively Iss **3** (& later) PCB versions, however it is almost impossible to guarantee that all earlier versions have been purged from the distribution chain.

**If in doubt contact Lascar to verify Issue No and/or application, BEFORE installing your SP 400 panel meter.**

**Q10. Help ! I've tried to follow all your suggestions, but I still can't get my meter to work. What do I do now?**

A10. Below follows a brief trouble-shooting guide. It would be beneficial to work through these basic checks, before requesting assistance from one of our application engineers.

**CAUTION:** For brevity we have omitted detailing all procedures in full, however suffice to say. Ensure any wiring or connection changes are made with the system fully powered down. Ditto continuity & s/c checks of wiring etc.

If you have a spare meter, try substituting this one, but if it shows the same symptoms remove it immediately, as if you have a serious wiring or application problem, you can easily destroy your spare unit. All meters are calibrated and subject to at least one full functional check before despatch, (in fact many are also subject to an extended burn-in), so it is extremely unlikely you could have received two faulty units.

Voltage measurements need to be made with unit(s) in-situ, and powered up. We recommend using a quality battery powered DMM, (to ensure reliable, isolated measurements), for most basic checks. However be aware that these tend to average a.c., and you may need access to a 'scope, to see the true "picture". At all times ensure that safe working practices are rigorously adhered to. In particular beware of hazardous voltages ! Especially in installations involving multiple meters !

### **Single Meter Application**

1). Is there anything visible on the display?

If not, check the wiring and polarity of your power supply.

Is it switched on?

Is the meter the correct model number?

Have you verified the wiring against the latest copy of the Data Sheet?

Is the meter plugged-in the correct way?

Try using a DMM to verify the polarity and supply level to the meter when in-situ.

Is it the correct level for the meter you have installed?

Does this change substantially when the meter is removed ? - If so, most likely you either have :

- A serious wiring error. Switch off immediately & check it.
- Damaged the meter. Try swapping it, if you have a spare.
- A poor connection to the power supply. Try removing the meter, and substituting a resistance to represent the load, (e.g. c 10K LCD "s-type", 50K non "s-type" or 27R LED, DPMs).

If the supply measured at the connections to the meter, still falls substantially when the (dummy) load is applied, this would confirm poor connection, dry joint(s) etc. If not, this would point to one of the other two issues above.

If all appears O.K., but still there is no display then probably, the meter has been damaged.

Check also that the meter you are using does not have Digital Hold or Display Inhibit, in which case check that the voltage present on the Hold/Inhibit pin does not correspond with the level required to enable this function.

Try also using the (Display) Test pin, (if available).

Finally try removing the meter from the application, and plugging it into a simple test circuit, as described in 7). below.

2). Is there some kind of reading on the display, or is it just random segments?

If it appears that segments are random, check :

- Meter is plugged-in correct way?
- Power Supply in particular, and ancillary wiring to meter is correct ? (see section 1). above).

If readings appear to be valid identifiable numbers, even if unstable, "over-range", too high, too low, or not appearing to respond to inputs, it at least suggests that the polarity of supply is correct. Make sure that the Power Supply Voltage at the module's connection pins, is within the limits specified on the data sheet, and proceed to the next section of the fault-finding procedure.

If however, nothing obvious comes to light from these checks, try removing the meter from the application, and plugging it into a simple test circuit, as described in 7). below.

- 3). Check the reference connections. In general for the majority of (standard) Lascar DPMs the reference voltages ( $V_{REF HI}$   $V_{REF LO}$ ) should be :
- 3.5 Digit types : 100 mV
  - 4.5 Digit types : 1 V

(Other more specialist types have different reference voltages).

However the key thing here, is stability, the reference voltage should be stable, and not alter significantly with supply, input, or temperature variations etc.

(Assuming of course all of these remain within the specifications quoted on the relevant module's data sheet).

If you cannot measure any voltage across the reference inputs, (generally termed REF HI & REF LO), or this is not stable then this is almost certainly the cause of your problem.

If the reference voltage (100mV typ) is present and stable, then go to 5). below. If the reference voltage appears to be around twice it's correct level, (characterised often by the DPM reading around half of the correct value), then check that AN COM has not inadvertently been connected to 0V (DGND etc). Most often this happens when customers try to use the fully floating application circuit for an application where one of the inputs is already referenced to the DPM. (e.g. A single-ended input to a "S-type" meter).

- 4). Check the level of AN COM. The Analogue Common connection, on most Lascar DPMs has a dual purpose. (Whilst it's original function was to provide access to the integrator reference level of the internal A/D converter, to avoid Common Mode Input Voltage errors, this is no longer necessarily the case). However :
- It does serve to set the input and reference levels in fully floating applications.
  - Also for many panel meters it forms the default internal reference voltage.

Check the voltage between AN COM and V+. For most meters and applications, you would expect to see between 2.8 and 3.6 V, between these two pins. (Note, for some applications and some 4.5 digit meters, AN COM is deliberately pulled down. Often to 5V below V+, but not necessarily).

Should you not be able to measure any voltage between V+ & AN COM, this is indicative of damage to the DPM, or possibly a connection s/c between these two pins. Switch-off & check immediately.

Assuming AN COM is the right sort of level (2.8 to 3.6 V below V+), then check to see if REF LO is also at this level. Also for meters with a REF- output, this again should be connected to the same level, for most applications.

Be aware that it is often difficult to tell if two points are at the same voltage level with a modern DMM, if one is floating, so either switch-off and check for continuity, or refer the measurements to a different known level (e.g. V+).

Assuming AN COM, REF-, & REF LO, appear correct, verify that the reference voltage between here and REF+ is the correct level, (as detailed in section 3). above). Now check to see if this same voltage is reaching REF HI. If not then dependant upon model, you may need to make a link, or hardwire to the connector.

[Aside : Due to the large variety of DPMs that Lascar produces, both current and legacy types, it is almost impossible to give generalised connection advice, applicable to all types of meters. However starting with the most configurable types, in essence what we are trying to do with the reference circuitry is this :

- i) Bias the reference circuit by connecting REF- to AN COM.
- ii) Connect REF LO to this reference point (AN COM).
- iii) Tap-off reference voltage from REF+ of divider chain.
- iv) Connect this reference voltage (REF+) to REF HI.

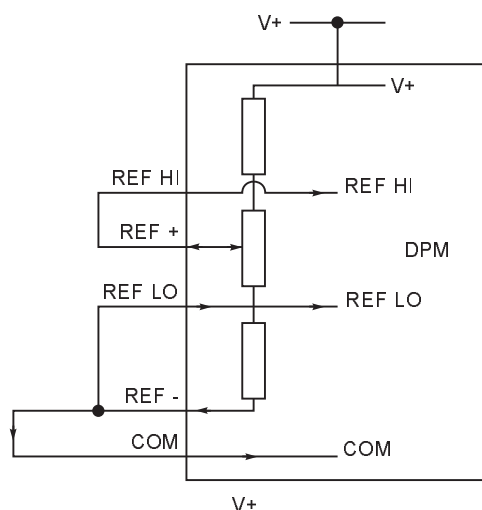

Hopefully this will give you the necessary information to verify the reference circuitry is connected & functioning correctly.

- 5). Check Input Levels. Try shorting the inputs together, (Make sure at least IN HI is isolated from your application circuit before you try this). Does the meter read zero, (or close to zero)?

Wild fluctuations would suggest that the inputs although zero'd with respect to each other, may be floating with respect to the DPM. For fully floating applications, typically IN LO needs to be connected to AN COM, to establish the correct level.

Other possible causes are noise on power supply and/or inputs.

(Try a capacitor say 10uF from V+ to An Com).

Assuming zero to be O.K., remove the short & reconnect, measure the signal with an external DPM. Is it within the allowable input range of the Lascar DPM? If not it will display "overrange" this is typically a "1" or "-1", (although on some DPMs this is characterised by flashing zeros or display segments).

Note, it may be that the DPM you have features on board scaling, or you have scaled this yourself. If the meter zeros correctly but shows overrange with a normal signal, measure this signal, is this greater than the default FSR for the meter?

What happens if you reduce the input below the default FSR of the meter?

Does it start to respond correctly again?

Most likely in this case, the meter has either not been scaled, or a connection error has been made. Check the Link (typically denoted Link A), across the series scaling resistor (typically denoted  $R_A$ ), has in fact been broken. Check also that the parallel scaling resistor (typically denoted  $R_B$ ), is not open circuit. Usually you can trace this signal across the scaling network with your DMM (typical input impedance 10M), in contrast to the recommended scaling impedance for the DPM of 1M.

- 6). Power Supply / Noise Problem?

Assuming none of the above checks have already pin-pointed the cause, check the power supply to the DPM.

Is the power supply adequate?

(You may need to check this with a scope for a LED meter)

Is there a noise problem?

This is often characterised by meter reading correct value most of the time, but occasionally the reading jumping significantly, before resuming a constant level, or just general instability. Or sometimes failing to fully zero, when the inputs are shorted.

Try connecting a capacitor (10 $\mu$ F) from V+ to AN COM.

Next try disconnecting power supply to the meter, and replacing it with a battery fed supply. If instability disappears this would indicate noise be transmitted through your power supply.

Ideally we would recommend a good quality linear power supply be used.

If the meter starts to respond correctly, having previously been reading incorrect values, this suggests a wiring issue, in that the inputs to the DPM are referenced to your DPM power supply, other than by the DPM itself. Check the wiring, or try replacing the PSU with an alternative fully isolated type.

7). Test meter in isolation from intended installation.

This is the recommended procedure, when all else fails, in fact it is often a quicker approach than progressively working through the full fault-finding procedure with the unit in-situ.

Remove the meter from the application. (If you are using socket connectors as opposed to direct soldering, you can simply unplug it.

Now (again using connection sockets), connect the power supply pins (typically V+ & V- or V+ & 0V), to a battery, (or failing that a completely isolated linear power source). A PP3 / MN 1604 is ideal for non-“S-type” LCD DPMs.

Referring to the Lascar Data Sheet for the product in question, now make the necessary interconnections for the fully floating application mode.

Typically this would be AN COM to REF- to REF LO, with REF+ to REF HI.

Inputs would be to IN HI & IN LO, whilst IN LO would also be connected to AN COM (or 0V for some “S-type” meters).

Now try shorting IN HI to IN LO. Does the meter now zero?

Next apply an input corresponding with 0.5FSR of the meter, (typically this will be the same as across the reference inputs

( $V_{REF HI} - V_{REF LO}$ ), unless the meter has been scaled). Does the meter read 1000, or close to this value?

Try reversing the inputs. Does the meter display the same magnitude but with a negative sign?

Try also halving & doubling the input levels, and reversing the inputs at each level. Does the meter appear to respond in a linear fashion?

If yes to the above, then this is a good sign that the meter is functioning correctly, and the next step is to start substituting it back in the intended application.

If not, and assuming it is otherwise unmodified, then this is indicative of a fault. However, it is usually worth performing a few basic checks as outlined in 1). 5). Above, to verify wiring & other voltage levels are indeed correct.

Having proven the meter's function to be O.K., start substituting connections back to those of your original circuit, in phases, starting with IN HI & IN LO.

By progressively re-introducing first the connections and then the meter back into the intended environment, the nature of the wiring / application fault should become obvious.

#### 8). Transients etc

Whilst not strictly part of the basic fault finding process, the subject of transients, is worth a quick, or passing comment.

Although this is probably one of the most difficult areas to design-out, here are some suggestions.

- Be conservative with voltage breakdown ratings.
- Try to keep all connection wires short.
- Keep signal inputs away from other circuitry, especially digital, mains, or hf.
- Decouple both power supplies and signals to power supplies.
- Where longer signal connections are necessary, twist the signal wires together, as this will tend to cancel any noise that may be picked-up.
- Ensure that inputs cannot exceed power supply rails, even in fault conditions.

Use high-speed diode rail-clamps and series limiting resistors if necessary to provide additional protection.

- Do not assume that because a meter appears to function O.K. for a period of time under steady-state conditions, that this verifies the circuit / installation in all conditions.

## **Multiple Meter Application**

- 1). Try physically unplugging all meters bar one, does this single meter now function correctly?

If so, most likely your circuit has exceeded the common mode input voltage range of one or more meters, or you have inadvertently dragged the reference down, (characterised by the meter under-reading the expected value).

Now try plugging DPMs back in one at a time, until one or more fail to respond correctly. This should give you a pointer to the problem area.

- 2). If not, remove this meter also & replace one of the other meters. Does this fix the problem?

If so, it is likely that the first unit had connections or on-board links incompatible with the current single-meter test set-up. Try replacing meters one at a time until one or more cease to read correctly. This should give pointers to the wiring or circuit design that has lead to the problem.

- 3). If not, then having tried all meters individually, proceed with fault finding as detailed for a single meter, in the section above. - Hint try fault-finding on the meter that has the simplest interface and connections.

- 4). None of the above is a substitute for proper design & analysis of your circuit/interface to the DPMs, rather it may give you a pointer to a problem, or overlooked aspect of your design.

## **COUNTERS**

**Q1. I have a sensor with quadrature outputs I need to count pulses up in one direction and down in another?**

A1. Simply connect one output to count input and the other to the counters up/down pin. Be aware that your sensor's phase relationship only holds good for given rotation speed ranges. Small and slow movements backwards and forwards can give rise to false readings.

# SMART PRODUCTS: SM-1, C100 Series & MDM-1

## Q1. I cannot get my Windows HyperTerminal to work with my SM-1?

A1. Within "Properties" go to "Connect To" Set correct Com port. Set 9600,8,N,1 and no flow control. Go to "Settings" and then "ASCII Setup" enable the "Send line ends with line feeds". Before trying again, ensure that you 'disconnect' and then 'connect' to update the settings. The settings are now correct for the default settings of the SM-1.

Note: In Windows 98, Hyper Terminal does not in fact echo characters to the screen, (even if you have enabled this function).

## Q2. Can I have alternative annunciators on a SM-1 / C 100 / C 110 / C 120?

A2. Yes, the provision exists to programme the 3-character annunciator via the RS 232 port if none of the presets are suitable. A lower case u will display the  $\mu$  symbol.

## Q3. How can I obtain the peak value?

A3. The SM-1 stores the max and min values, which can be recovered by pressing either the up or down arrow keys during normal operation. The sampling rate is 4 times a second, therefore if the peak value is present for at least 250mS then it will be recorded, if less then that it may be missed.

If the peak signal to be measured, is a single pulse then it would also be possible to use a DPM with digital hold configured with a peak detect circuit. Suitable DPMs with digital hold are the :

DPM 116, DPM 100, DPM 970, DPM 959, DMM 939, DPM 160 & DPM 300.

## Q4. When using $V_{REF+}$ & $V_{REF-}$ to reference the MDM-1's onboard A to D, I get missing codes, what can I do to remedy this?

A4. When using  $V_{REF+}$  /  $V_{REF-}$  as a reference for the onboard A to D it is always a good idea to de-couple both of these inputs to 0V. We suggest capacitor values somewhere in the region of 100nF. Please also take note of the following absolute maximum ratings :

PIN	MIN.	MAX.
$V_{REF+}$	[V+] 2.5V	V+
$V_{REF-}$	0V	[ $V_{REF+}$ ] - 2.0V
(N.B. [ $V_{REF+}$ ] - [ $V_{REF-}$ ])	2V	V+)

# POWER SUPPLIES

## **Q1. What fusing should I use on a Lascar Linear PSU?**

A1. The value should be as specified on the data sheet. The fuse should be 5 x 20 mm and time lag (also referred to as Anti-Surge (T)), which complies with IEC 60127-2 sheet 3. The fuse holder should be compatible with the size of fuse, touch-proof (BS EN 60127-6) and be fixed in such a way that it does not pose a risk to users, installers or maintainers.

If there is likely to be a problem with mains borne transients, or other EMC problems, then it would be worth considering using a suitable mains inlet filter.

## **Q2. The power supply is getting very hot - why?**

A2. Power supplies can be used to their maximum output if they are at 25°C. In an enclosure it may get much hotter and you will have to take less out. Consult the data sheet and follow the de-rating curve.

# DATA LOGGERS

## **Q1. How do I measure Humidity on your Loggers?**

A1. The EL-1, EL-2 or EL-2-IR have provision for connecting a capacitive sensor, which must be in the range 200 to 300 pF with a sensitivity of 0.5 to 1.0 pF per %RH. The limitations are that the sensor must be close to the logger and in addition it is necessary to calibrate the sensor. Check Link 3 is open, Link 2 is shorted.

The low cost method of calibrating humidity sensors is to use special saturated salt solutions such as Lithium Chloride (11.3% RH) and Sodium Chloride (75.3% RH), which always have the same humidity. The solutions are put in a sealed container, with the sensor suspended just above, and left for half an hour to stabilize before taking a reading.

Alternatively Honeywell produce a range of sensors with signal conditioning (Farnell & RS stock several within this range) which can be used with all the loggers. These sensors provide a DC output of 0.8 to 3.9V, which could be scaled for the logger. They require a 4 - 9V supply. Please note the logger will not know if this supply has failed. If a battery is used then it should be changed regularly.

A third option is a sensor, normally within its own case, including active electronics and providing a calibrated 4 - 20mA output. This is best used with the EL-1-12bit, EL-2-12bit or EL-3-12bit that have a inbuilt 4 - 20mA loop detector, although an external sense resistor can be used with our other loggers. Please note the logger will not know if this supply has failed. If a battery is used then it should be changed regularly.

## **Q2. How do I measure pH on your Loggers?**

A2. The EL-1, EL-2 or EL-2-IR have provision for working with a pH electrode via a preamplifier. Check Link 2 is open. Typical suppliers of electrodes and preamplifiers would be Omega or Cole - Palmer.

The low cost method of calibrating pH electrodes is to use liquids called pH buffers. The typical values used are 4.0 and 7.0. The probe is put into one of the solutions and left for a minute to stabilize before taking a reading. Raise the electrode and rinse in de-ionised water before putting into the second solution. For test the calibration check with a buffer value of 5.0.

A second option is a sensor, normally within its own case, including active electronics and providing a calibrated 4 - 20mA output. This is best used with the EL-1-12bit, EL-2-12bit or EL-3-12bit that have a inbuilt 4 - 20mA loop detector, although an external sense resistor can be used with our other loggers. Please note the logger will not know if this supply has failed. If a battery is used then it should be changed regularly.

